

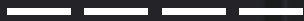

COR VISION



INSTALLATION
GUIDE

INSTALLATION GUIDE

IMPORTANT

The purpose of this guide is to ensure the highest quality standards in the installation of the Cor Vision Series.

Before starting the process, it is necessary to review all the steps to ensure that there is no loss of performance in the installation process.

The installation must be carried out and supervised by duly trained and qualified professionals.

It is important to ensure good leveling and plumbing of the door, whether it is due to irregularities of the support surface of the frames or if it is due to possible deflections of the structures that will support the weight of the system, in order to be sure the system works correctly and it does not appear anomalies in the rolling of the leaves.

Make sure that the building never transmits loads to the door.



Opening Possibilities

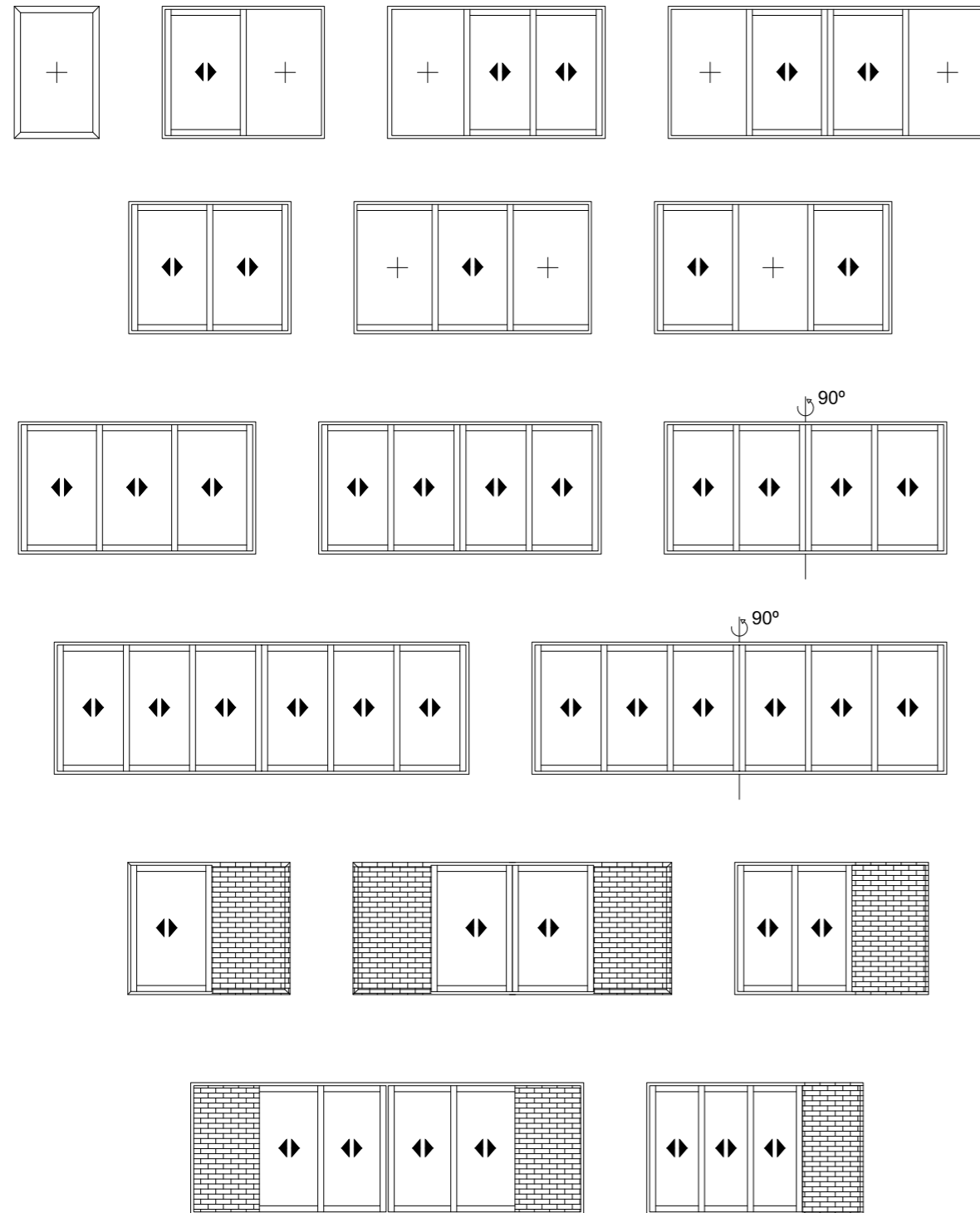

Cor vision Technical Data

Transmittance

$U_w \geq 1,3$ (W/m²K)

Please consult typology, dimensions and glazing

Acoustic insulation

Glazing Max. 30 mm / Min. 26 mm

Maximum Acoustic insulation Rw 41 dB

Sightlines

Frame 116 mm

Sash 37 mm

182 mm 3 rails

Profile Thickness

Door 2,0 mm

Polyamide Strip Length 16/24 mm

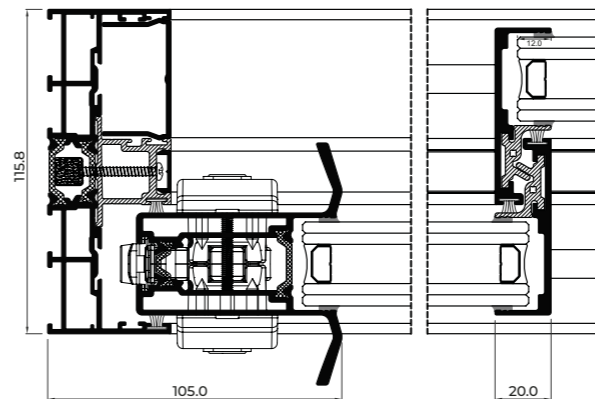

Features

Air permeability Class 4

Wind resistance Class C5

Water tightness Class 7A

Reference test 1,23 x 1,55 m / 1 sash + 1 fixed light

Finishes

Possibility of dual colour systems

Colour powder coating (RAL, mottled and rough)

Wood effect powder coating

Anti-bacterial powder coating

Anodised

Opening possibilities

Sliding

Possibility of 1, 2 or 3 rails

Possibility of interior and exterior

corner at 90° without mullion

Pocket possibility

Maximum Sash sizes

Width (L) = 2500 mm

Height (H) = 3000 mm

Consult maximum weight and dimensions according to typologies

Maximum Sash Weight 320 Kg



Outer Frames

COR 4388

HI frame for sash and fixed with stainless steel rail

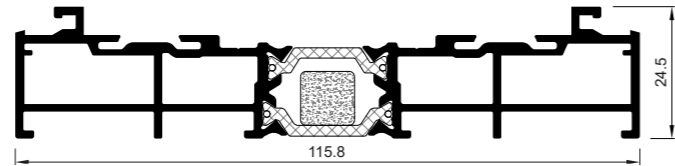

COR 4389

HI frame with stainless steel

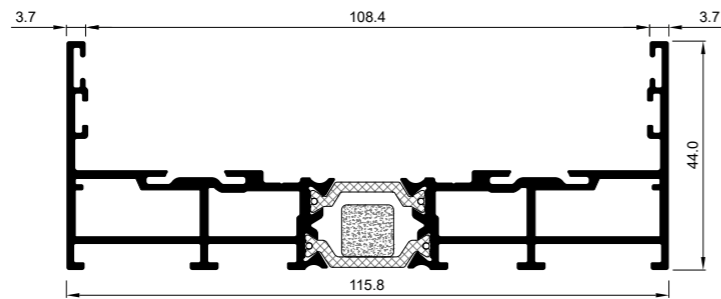

COR 4391

HI Three rail frame with stainless steel frame

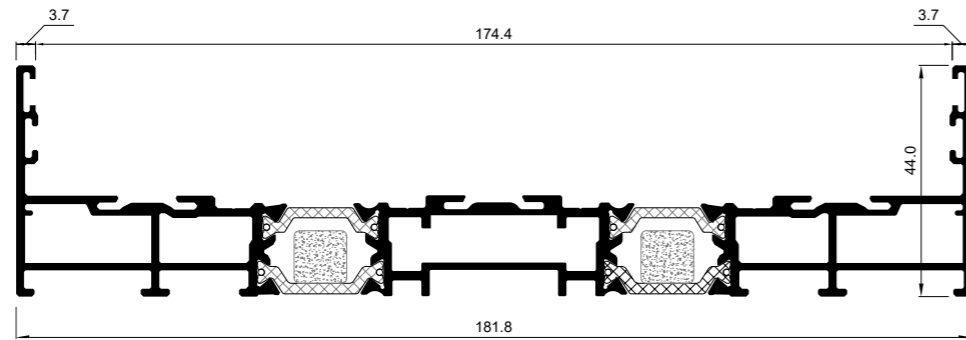

Outer Frames

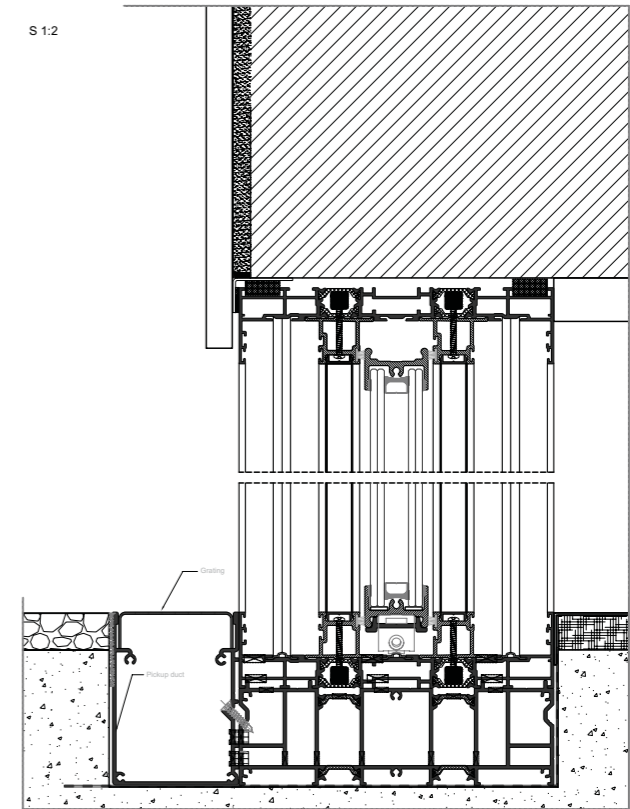

OUTSIDE

INSIDE

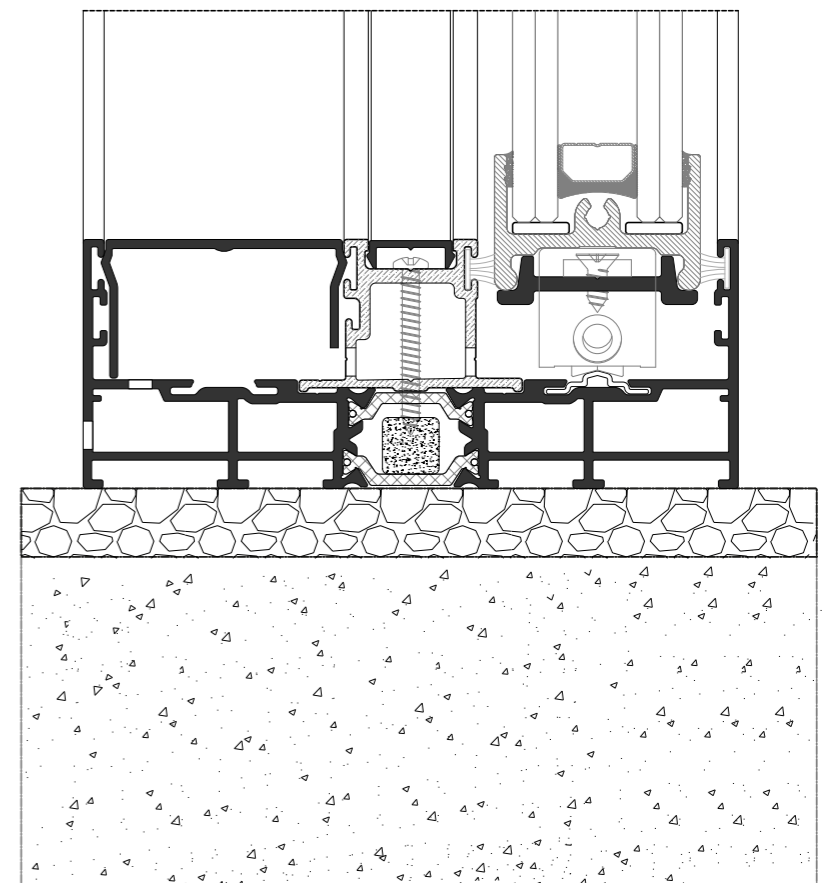

1. Prepare the opening

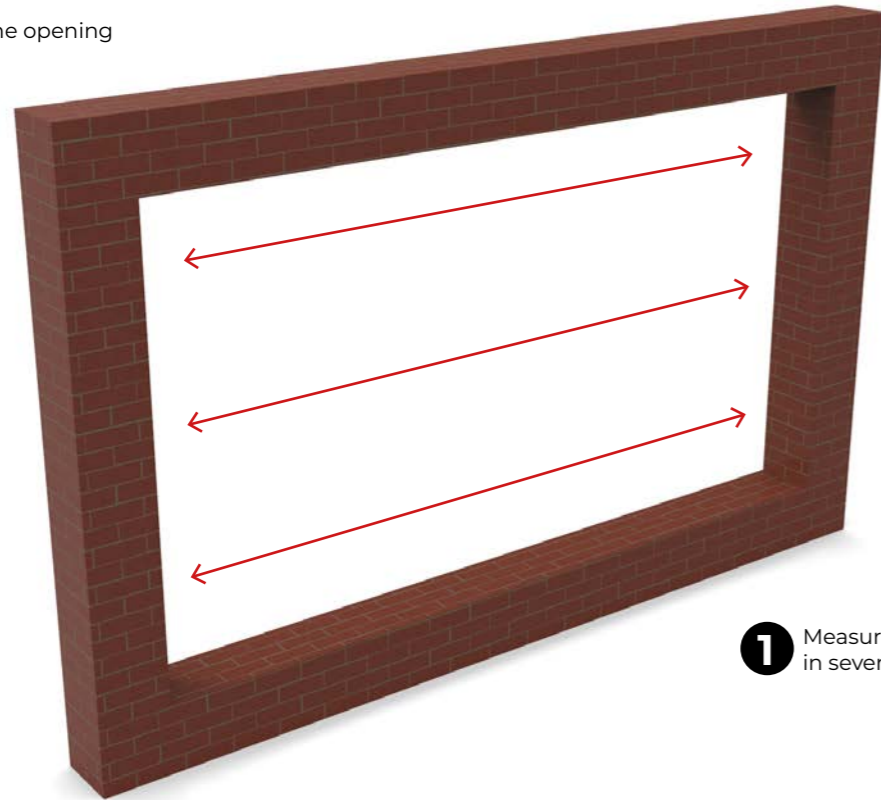

1 Measure width in several points.

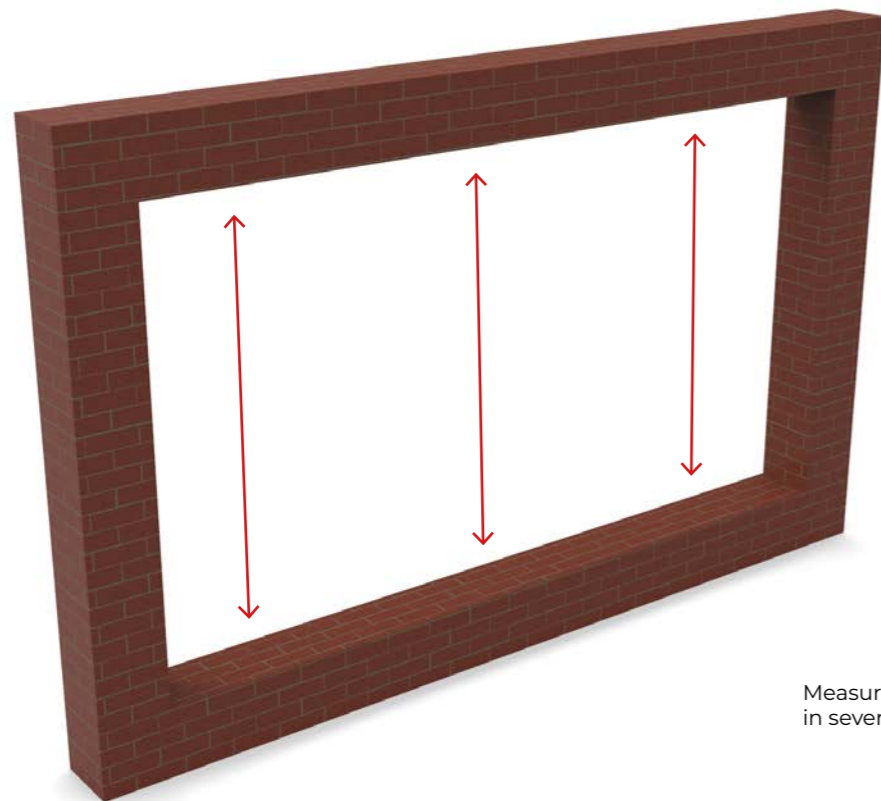

Measure height in several points.

2 Level the threshold in both directions, packing accordingly.

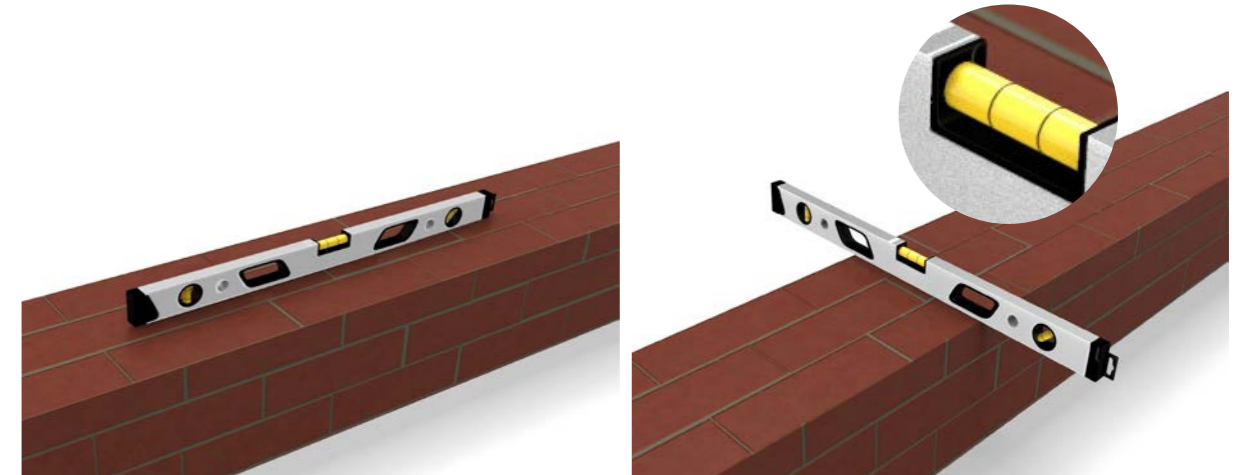

3 Lay frame profiles in front of opening, being careful not to scratch the paint.

2. If applicable, join the top/ bottom frame profiles together

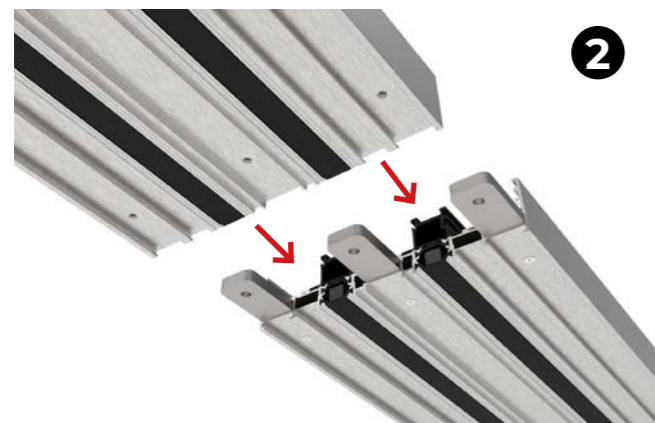
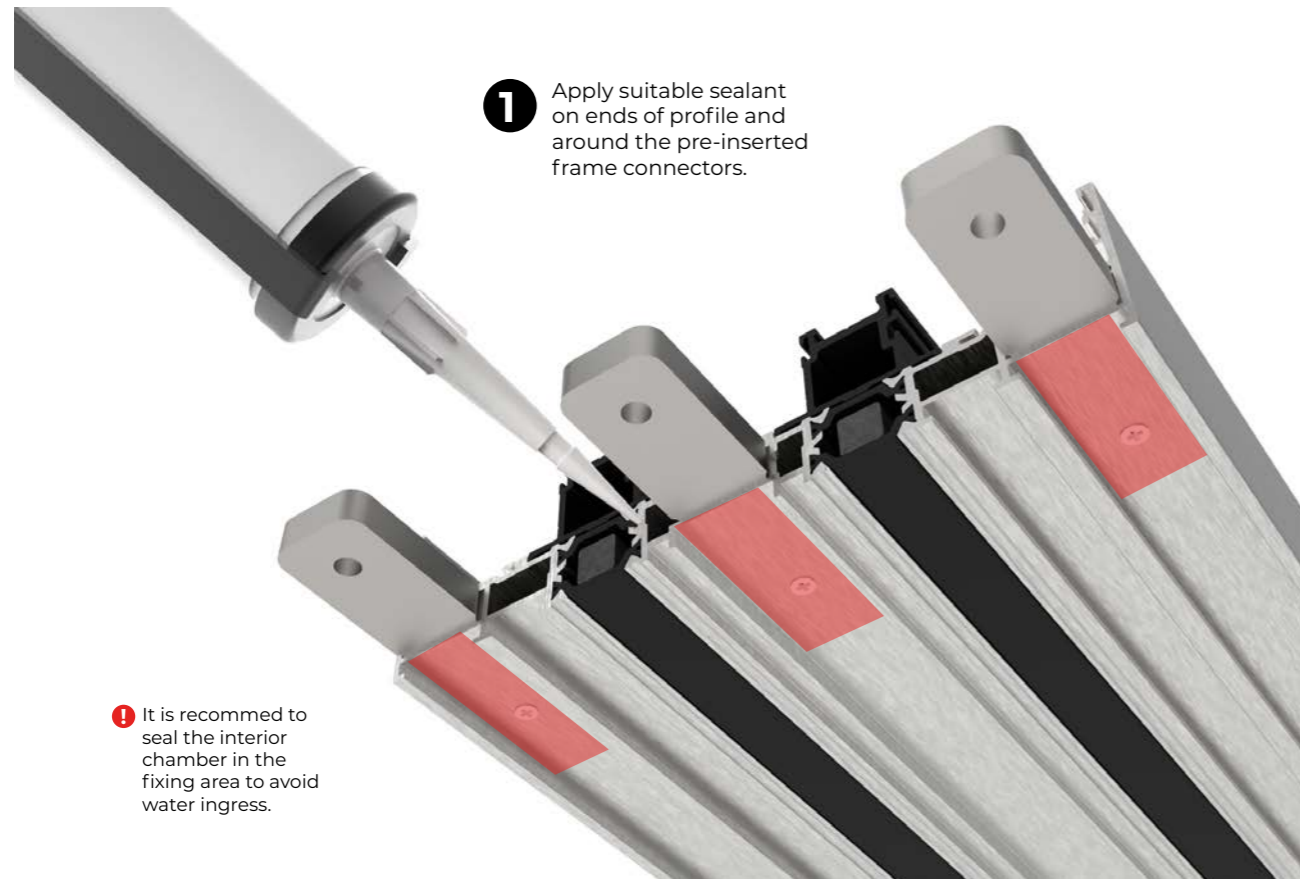

Connect the frame profiles together.

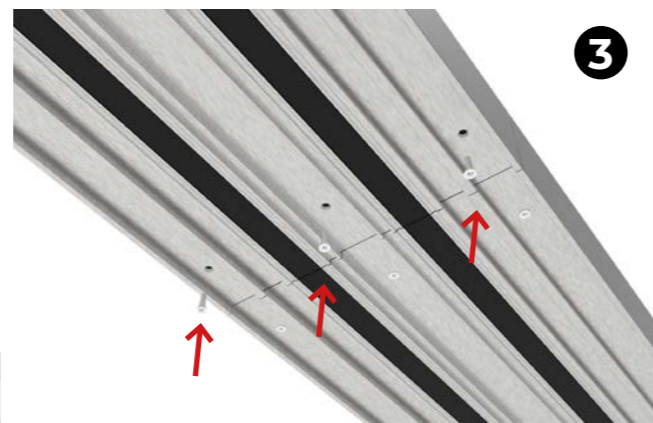

Fix the frame profiles together and repeat for remaining frame pieces

3. Connect the jambs and bottom track



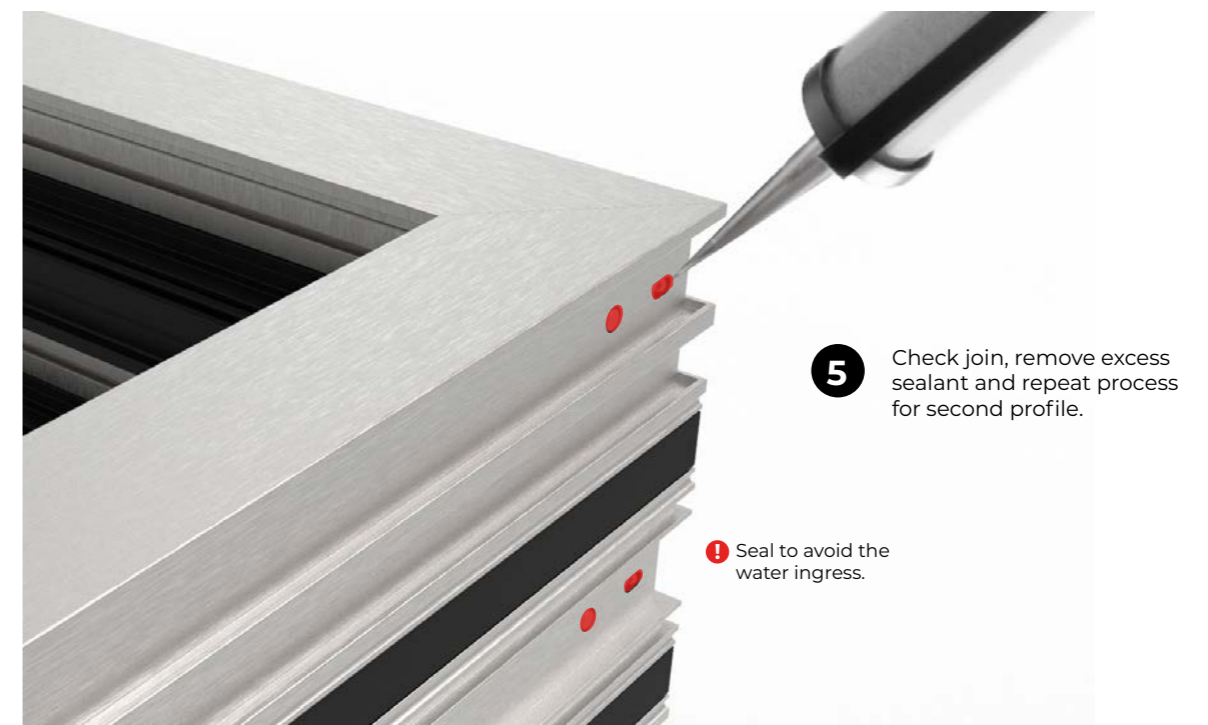
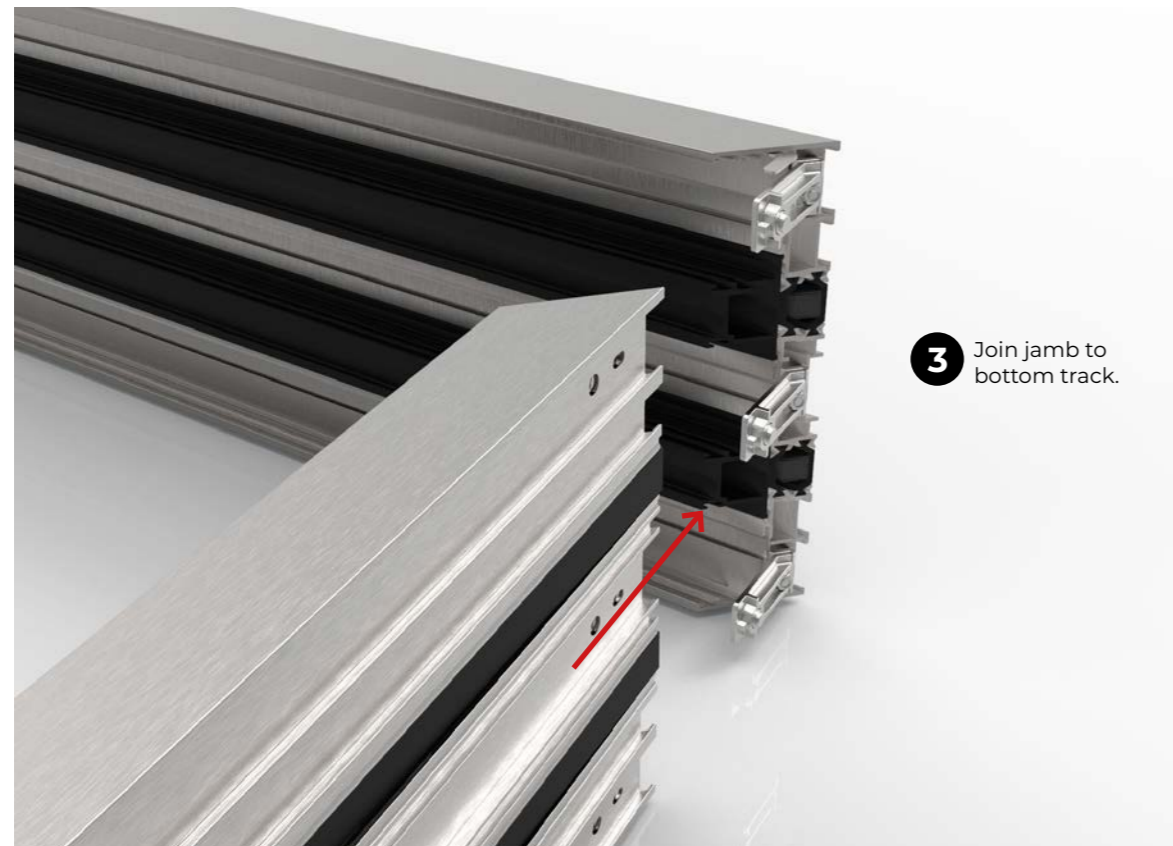

4. If applicable, connect the fixed interlock (only applicable for sets with fixed panels - monorail)

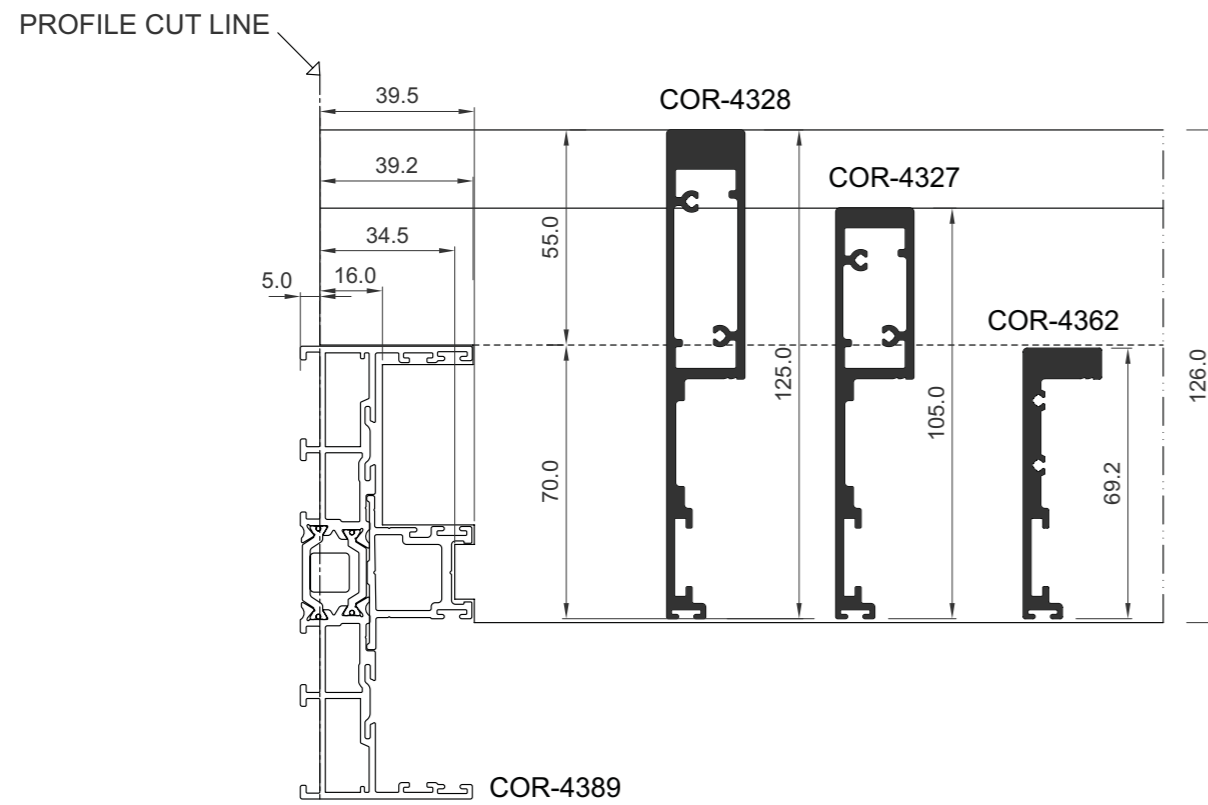

Note: Flush fixed interlockers do not require end plates.

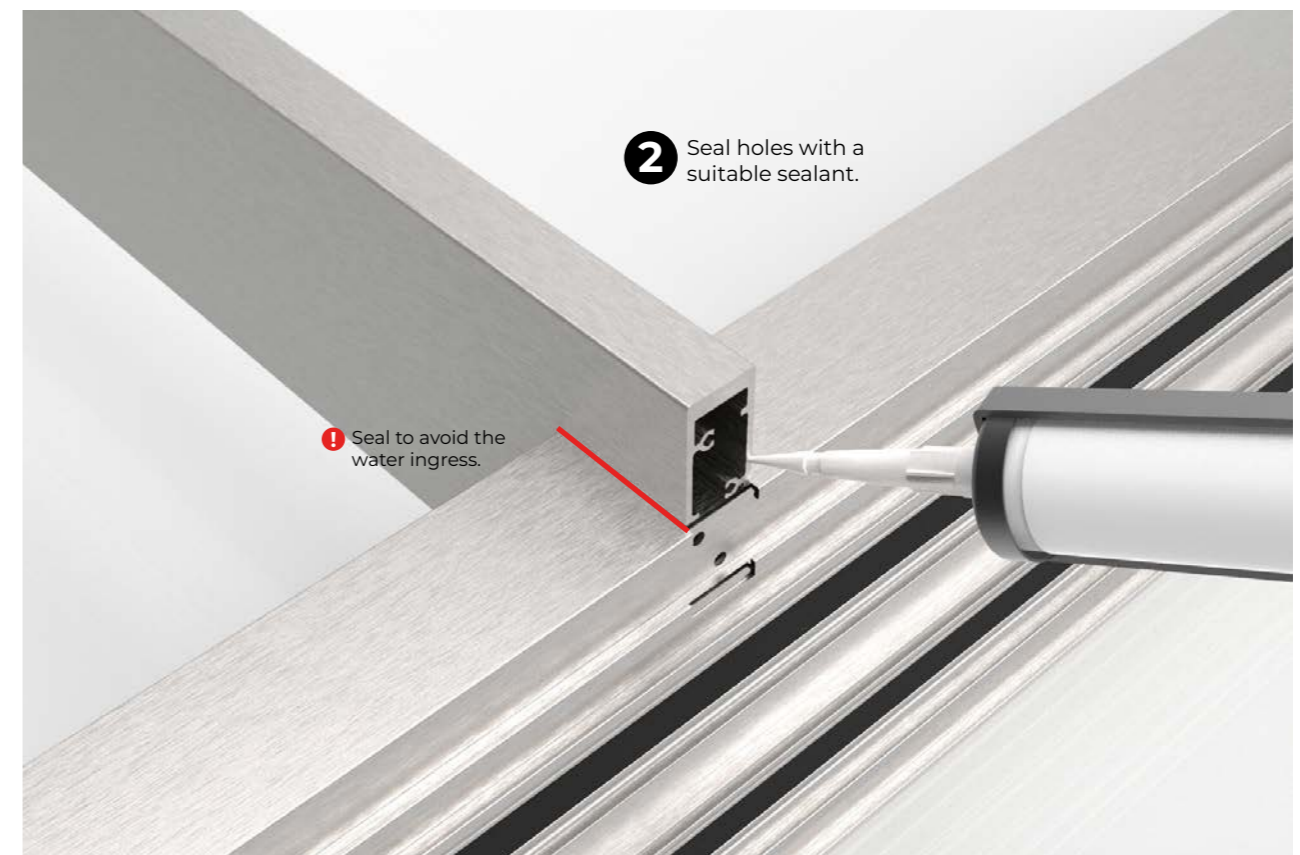
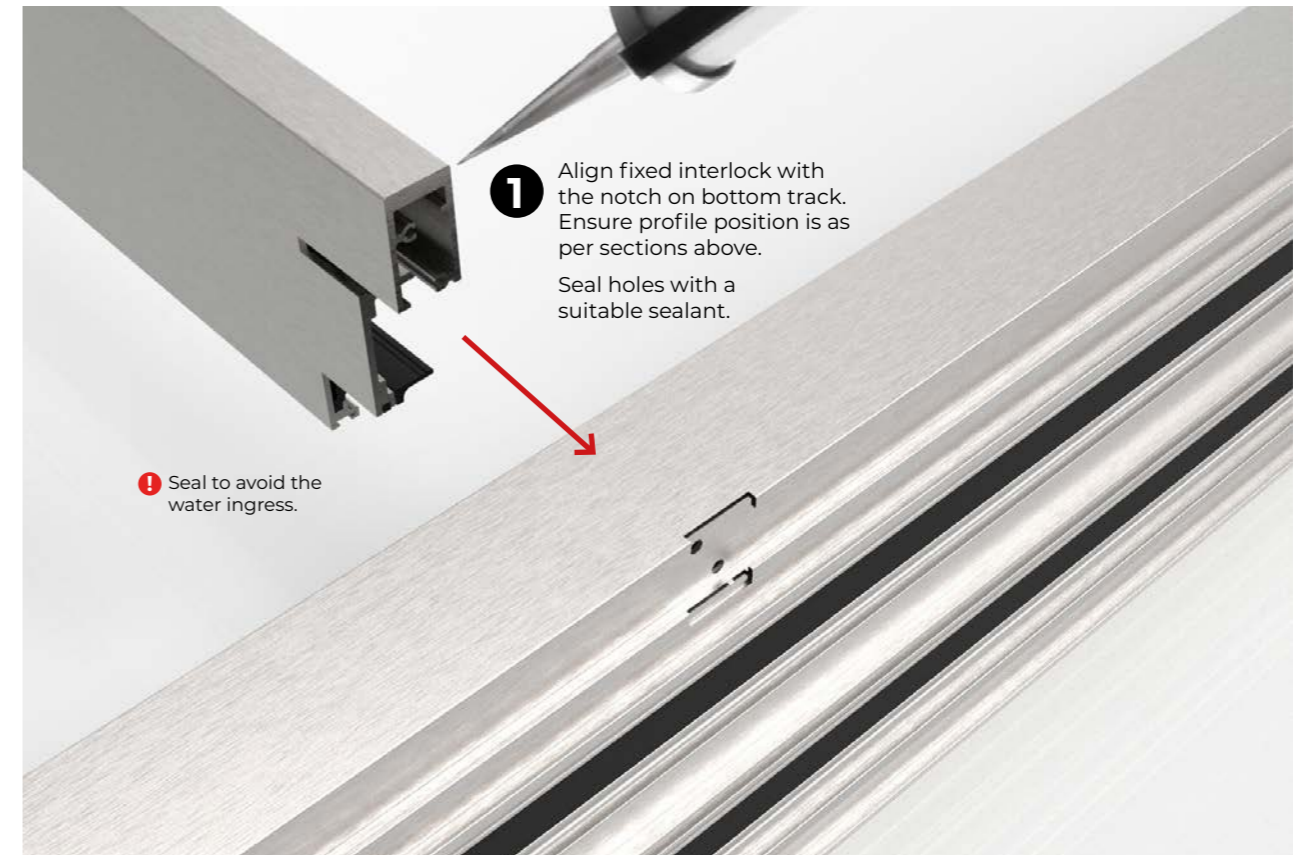

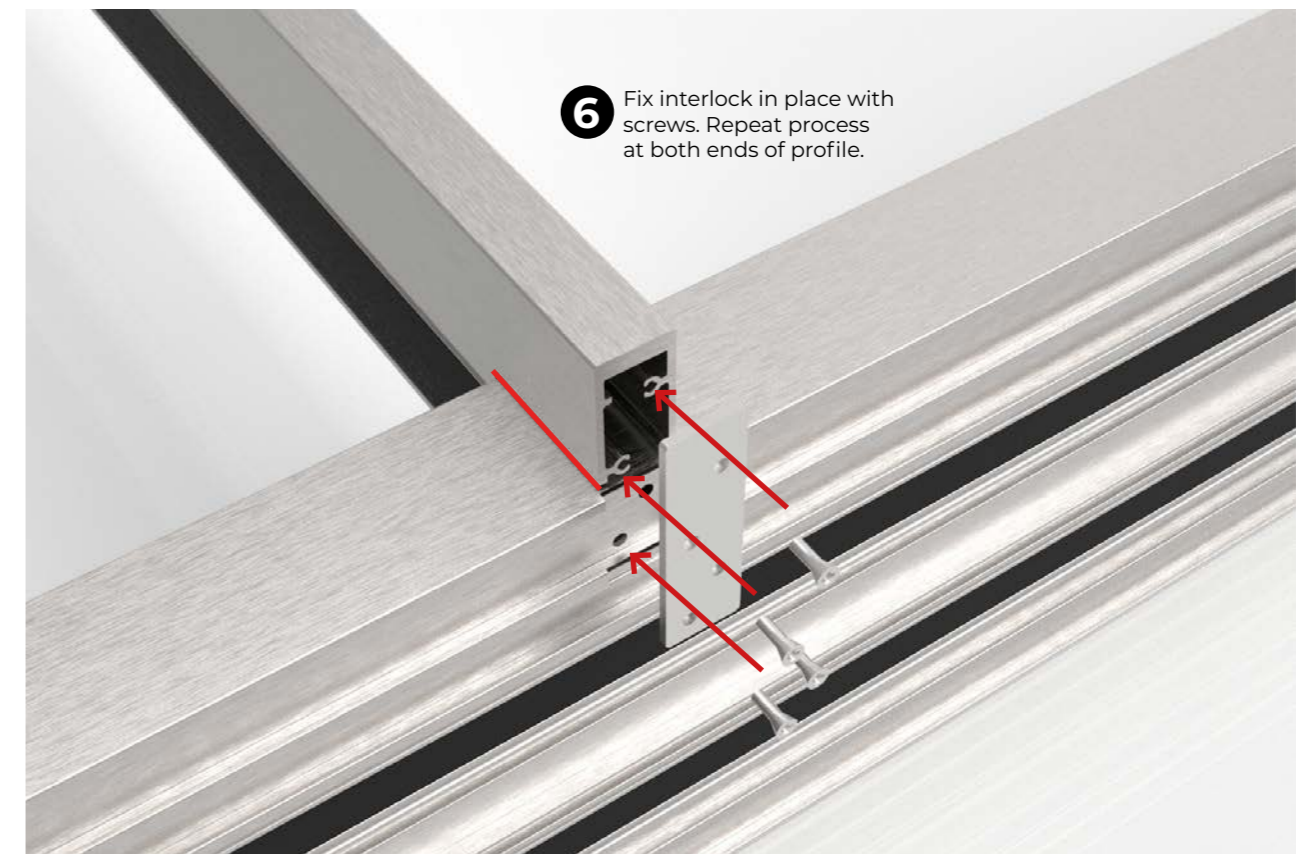
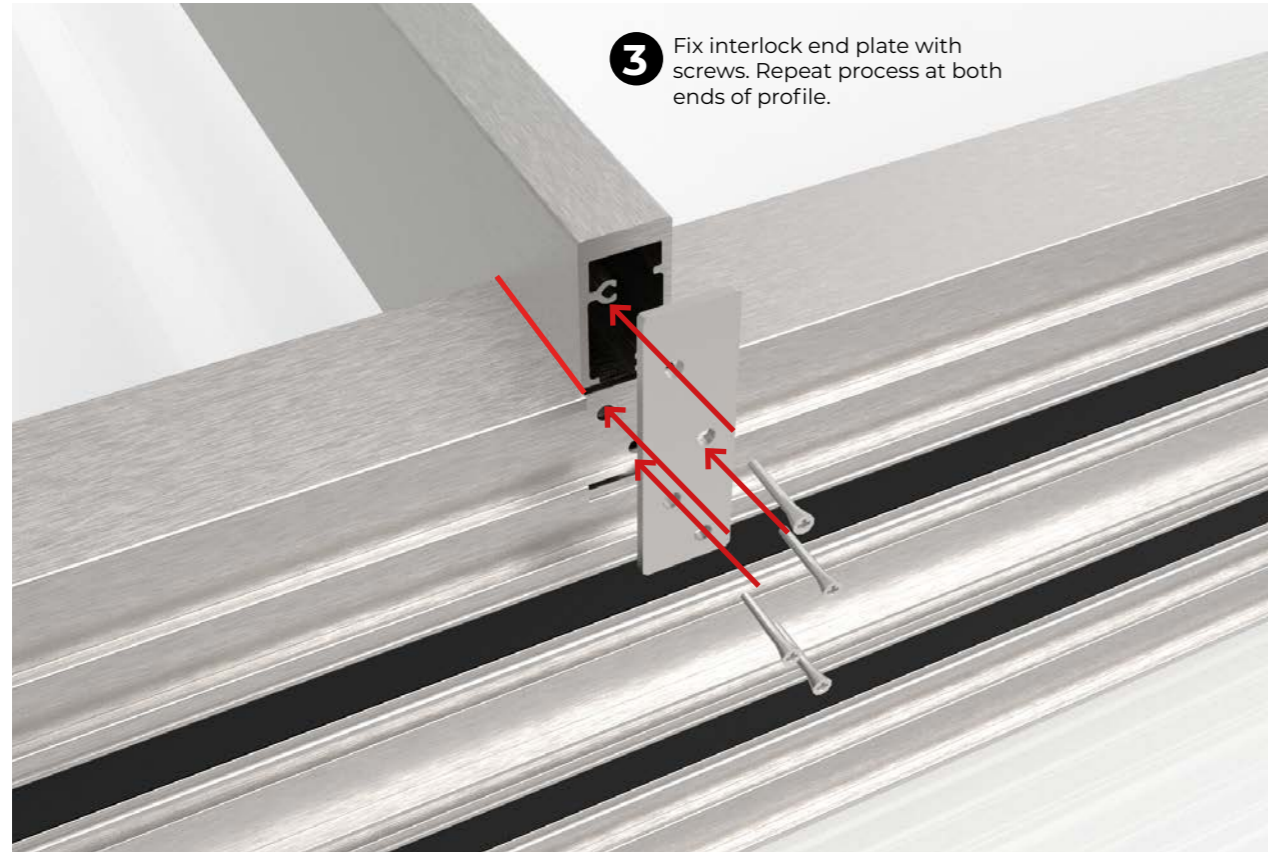



When fixing the frame to the structure the separation between screws must not exceed 600 mm. The depth of the screw on site should never be less than 30 mm. (See table with recommendations for use)

The fixing of the shoe can also be carried out by the use of fixing slugs.

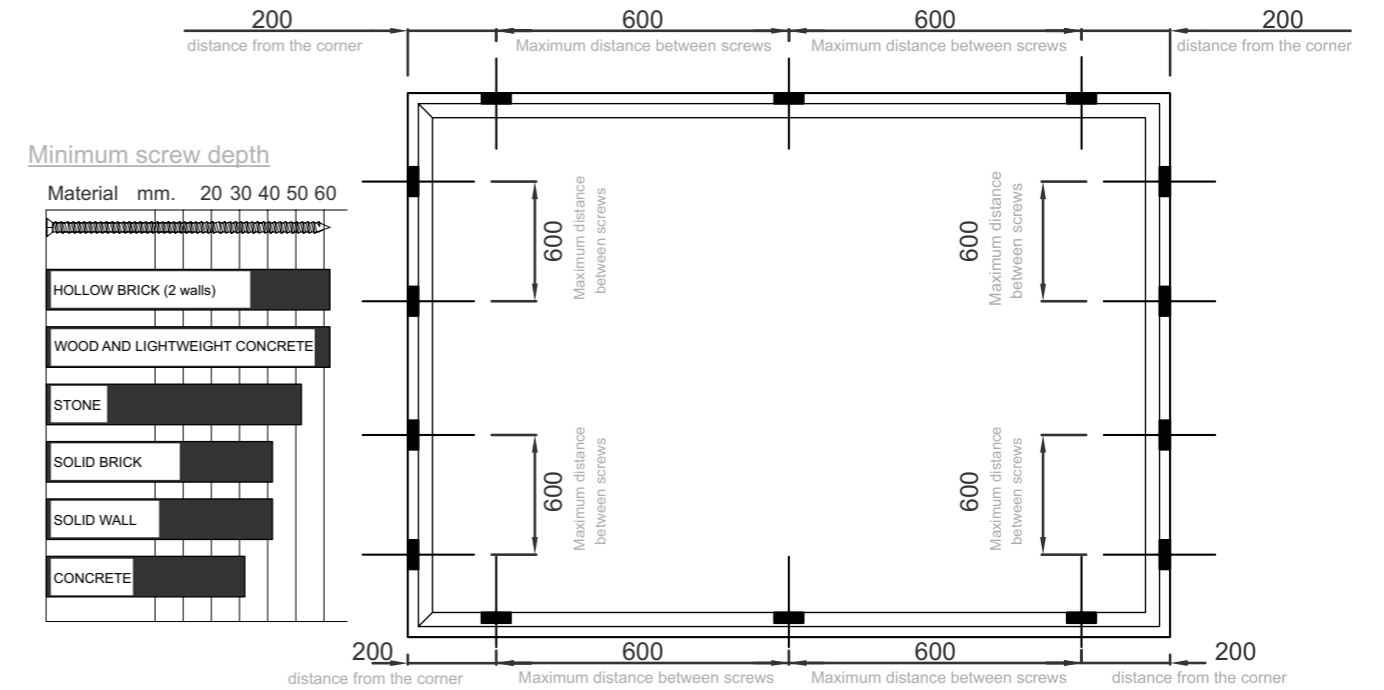

5. Lift the frame into the opening

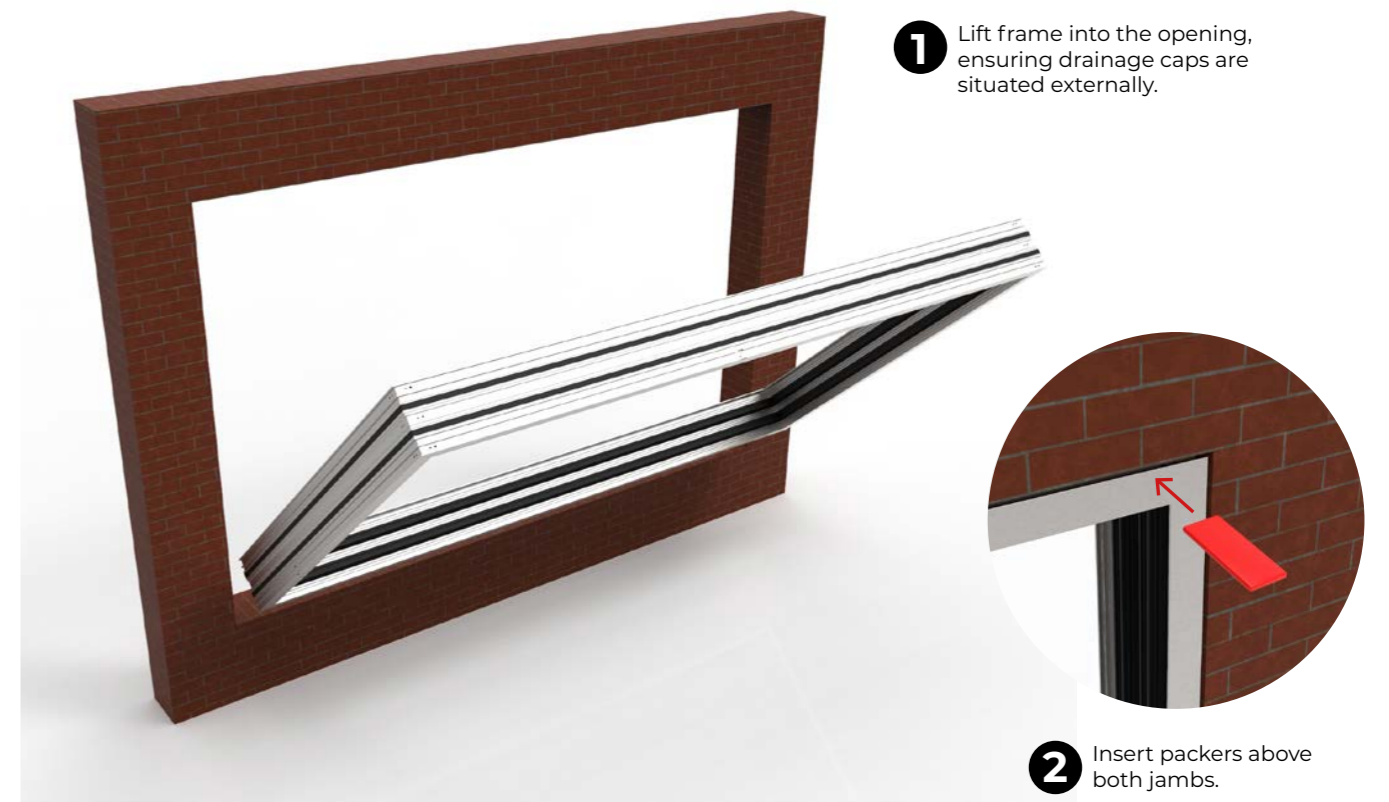

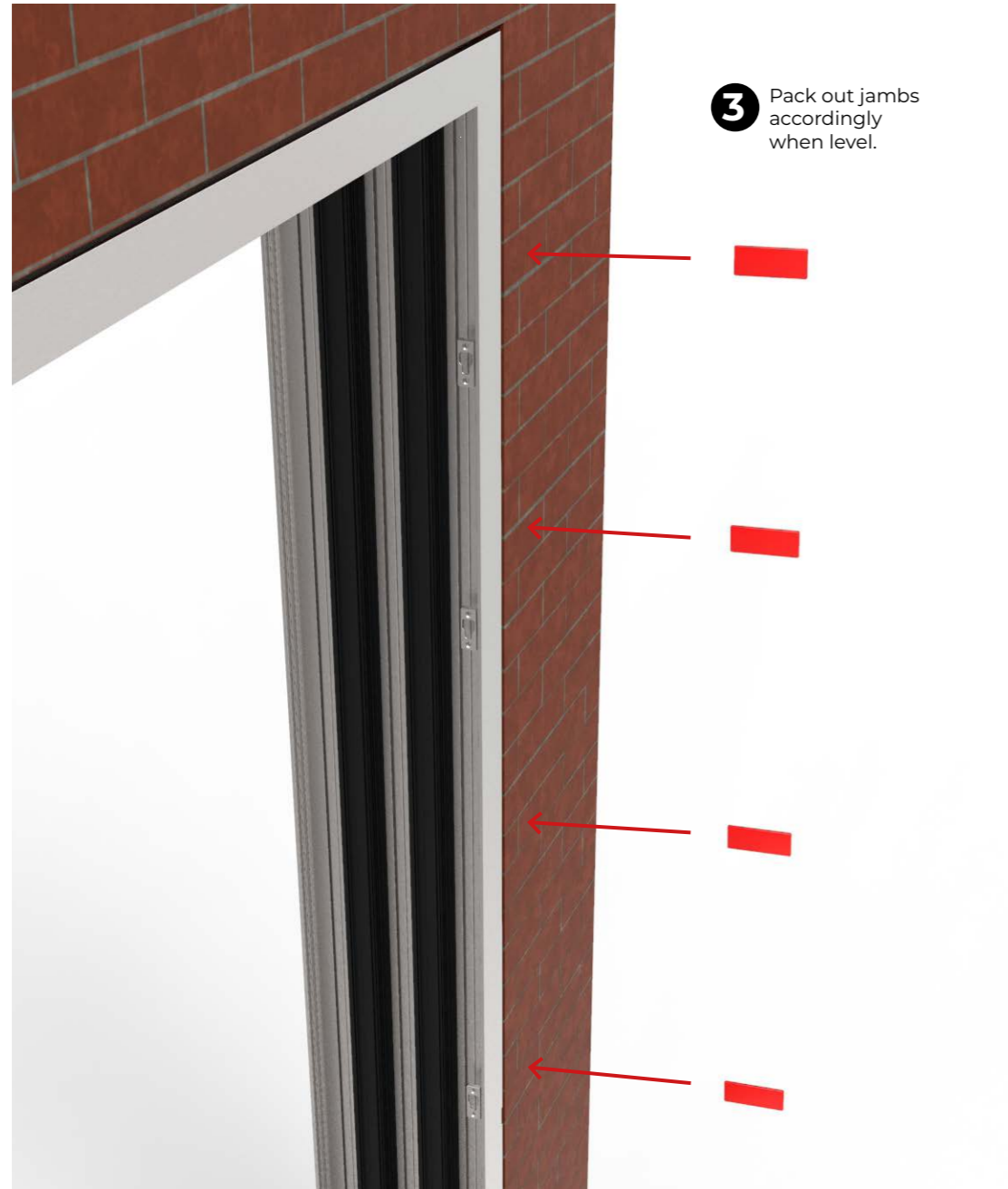

3 Pack out jambs accordingly when level.

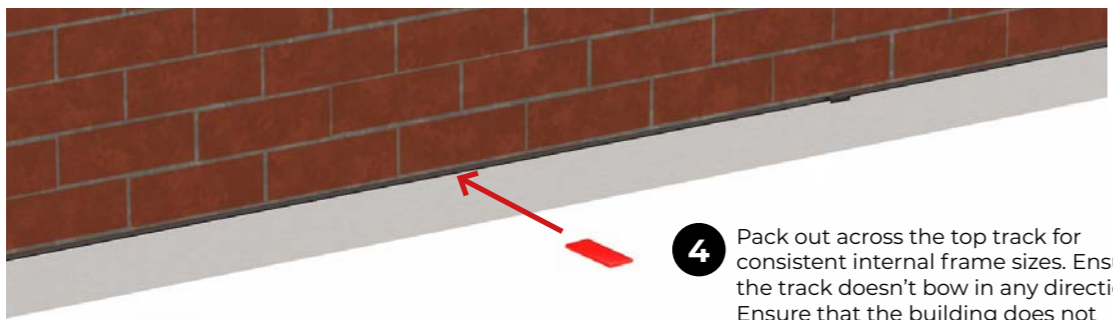

4 Pack out across the top track for consistent internal frame sizes. Ensure the track doesn't bow in any direction. Ensure that the building does not transmit any loads into the frame.

6. Level and fix both jambs



1 Level out jambs in both directions.

7. Fix the bottom track

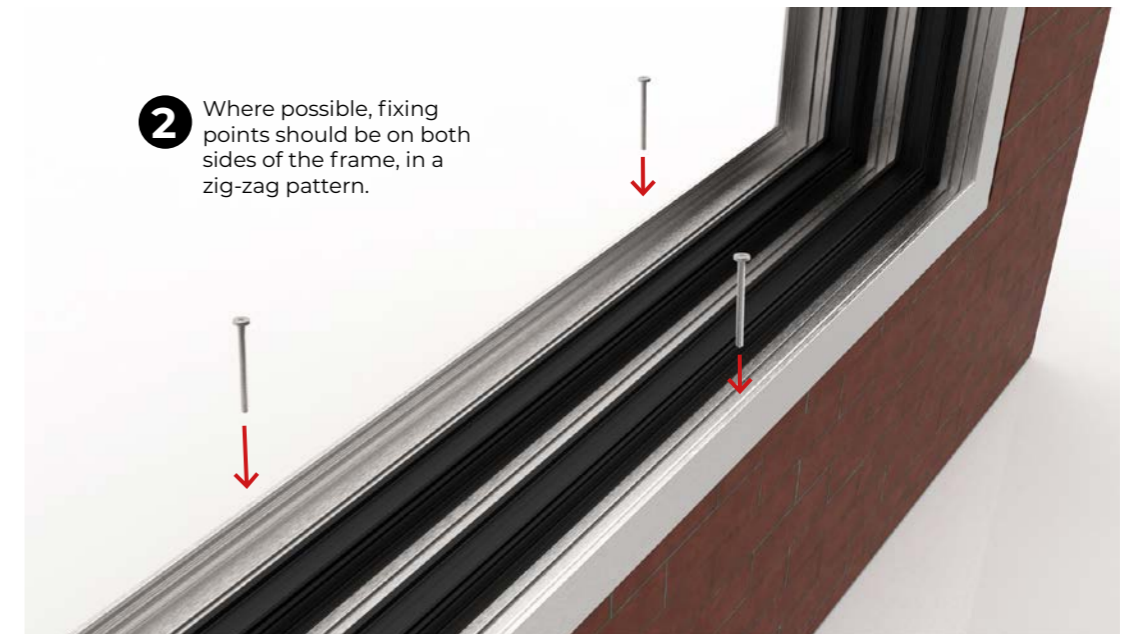

2 Where possible, fixing points should be on both sides of the frame, in a zig-zag pattern.



3 Drill an appropriate sized fixing hole through the frame. This should be no more than 200 mm from the external corner of the frame.



4 Insert suitable sealant to fixing hole, then screw preferred fixing in place. Repeat process along the bottom track, ensuring fixings are within 600 mm intervals.



5 Drill an appropriate sized fixing hole through the frame. This should be no more than 200 mm from the external corner of the frame.



6 Screw preferred fixing in place. Repeat process along the jambs, ensuring fixings are within 600 mm intervals.

8. Fix the top track



7 Drill an appropriate sized fixing hole through the frame. This should be no more than 200 mm from the external corner of the frame.

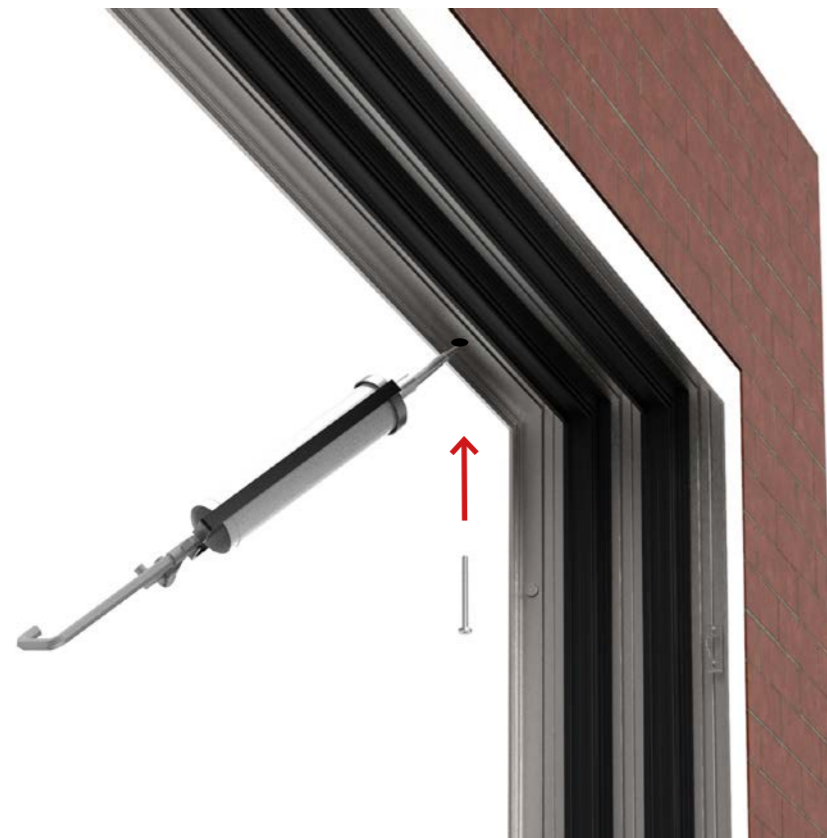

8 Insert suitable sealant to fixing hole, then screw preferred fixing in place. This must be done at both ends of the top track.

9 Accurately measure the internal frame dimensions.

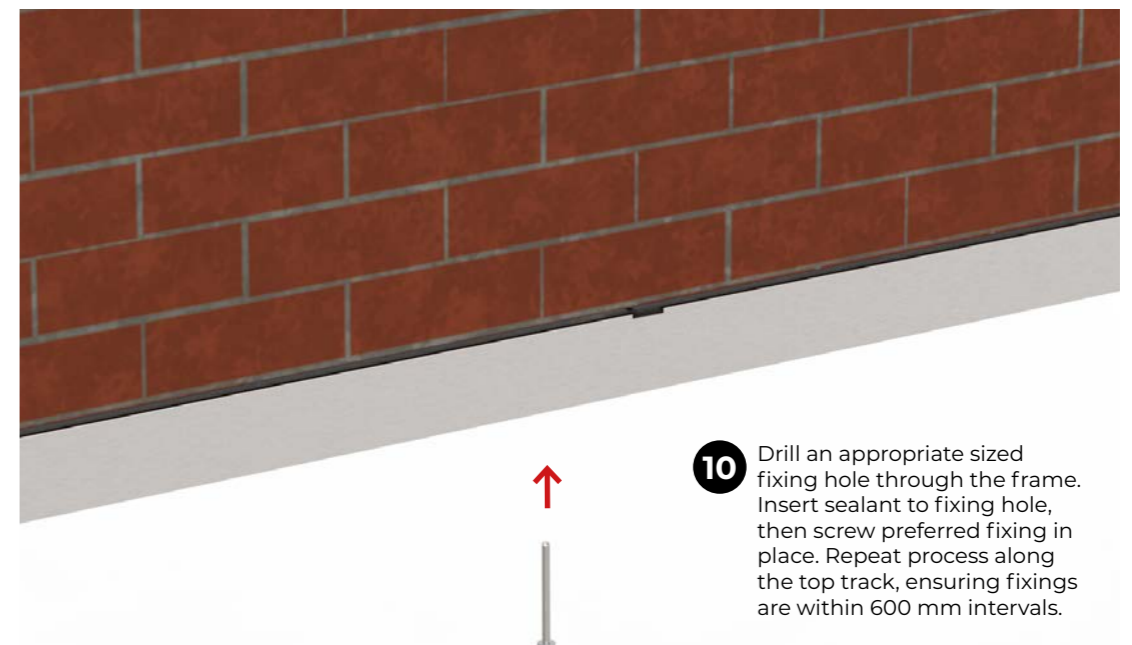
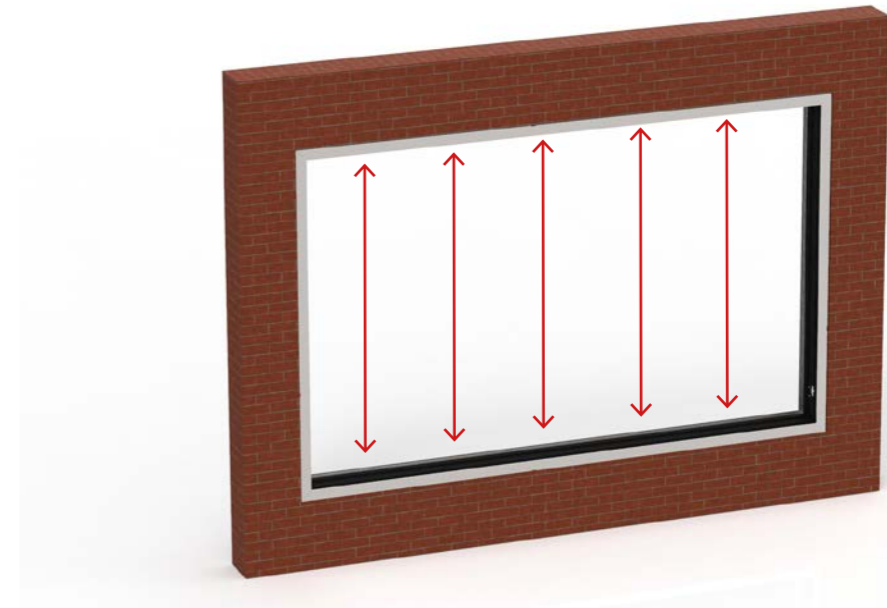

10 Drill an appropriate sized fixing hole through the frame. Insert sealant to fixing hole, then screw preferred fixing in place. Repeat process along the top track, ensuring fixings are within 600 mm intervals.

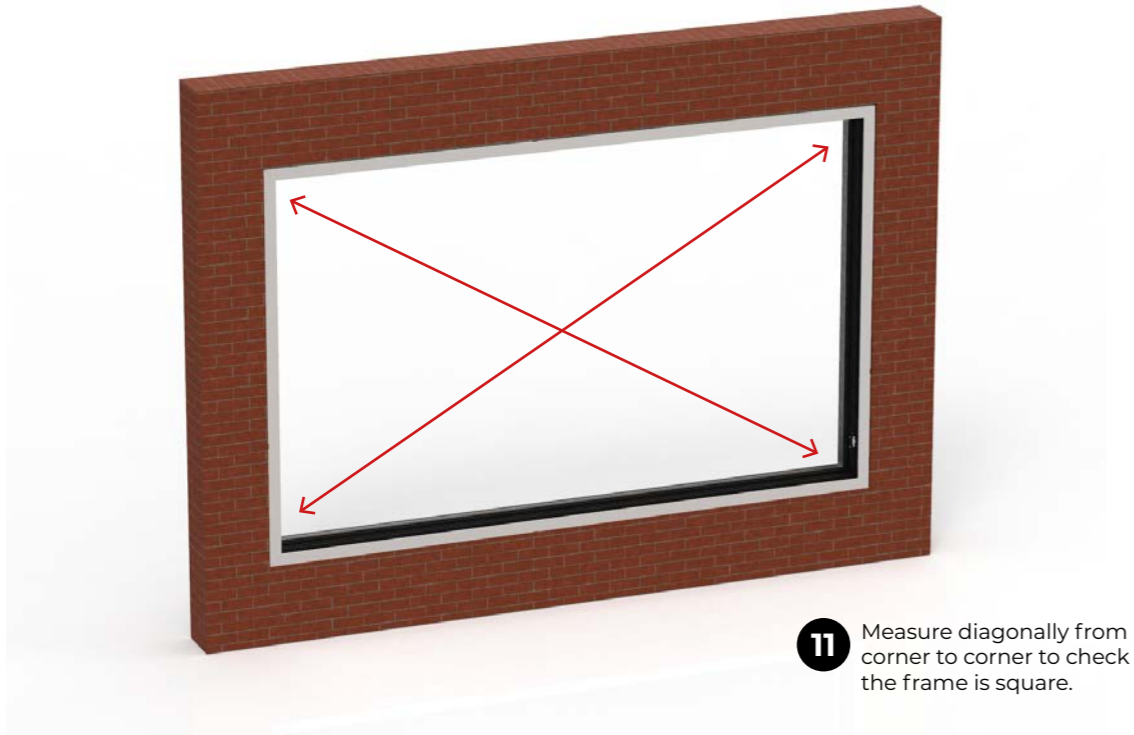

11 Measure diagonally from corner to corner to check the frame is square.

Fixing verticals and upper horizontal frame profiles must be done by the interior and exterior part of the profile, for this it is possible to position the screws with a staggered pattern, respecting the maximum separation.

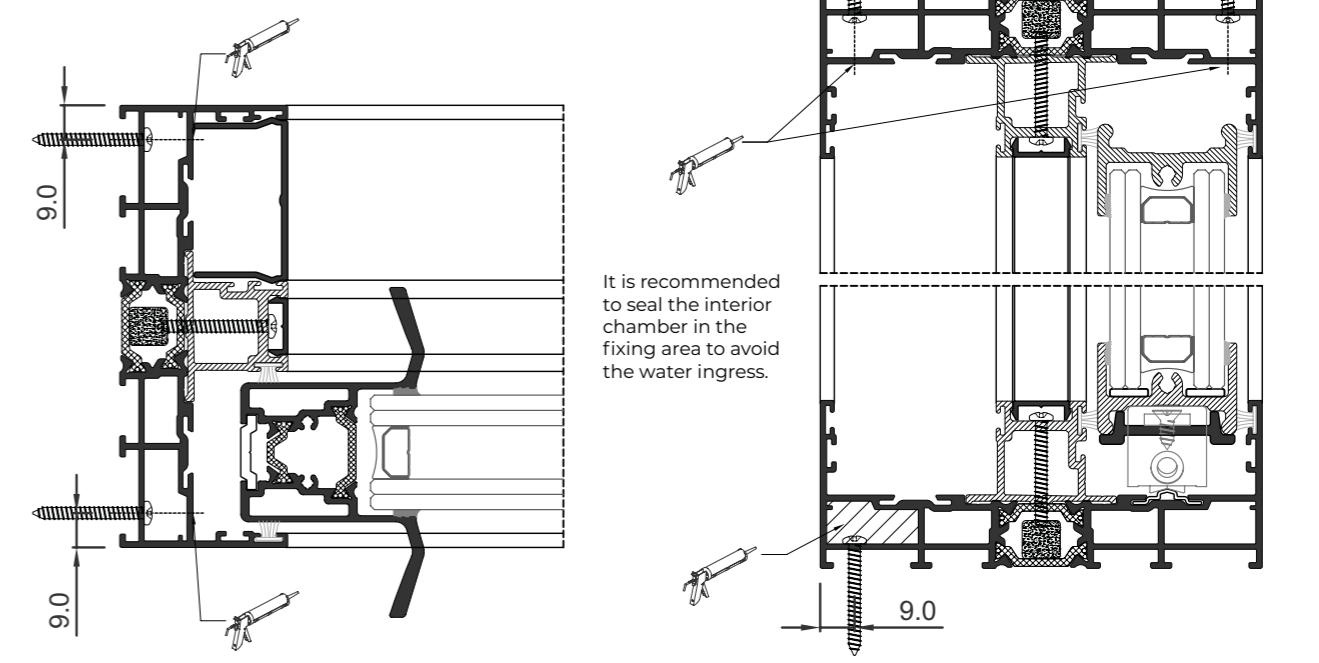

12 Seal the drainage isolator in place, ensuring ends of profile are sealed with edge of frame.

Installation Guide

9. Install the sash

- 1** Insert all bearing with rollers into necessary track channels.

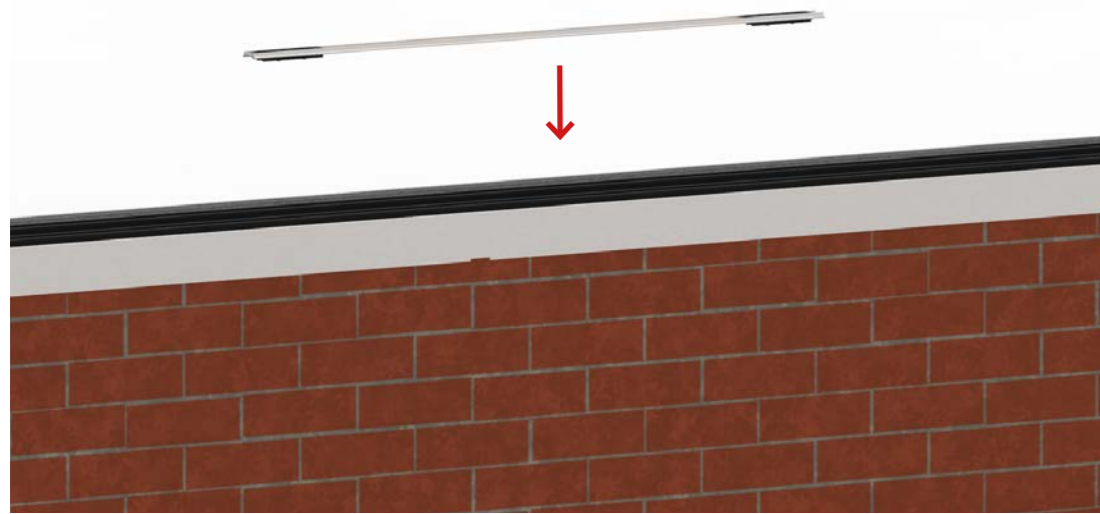

Adjust the wheels with an allen key after the sash has been installed

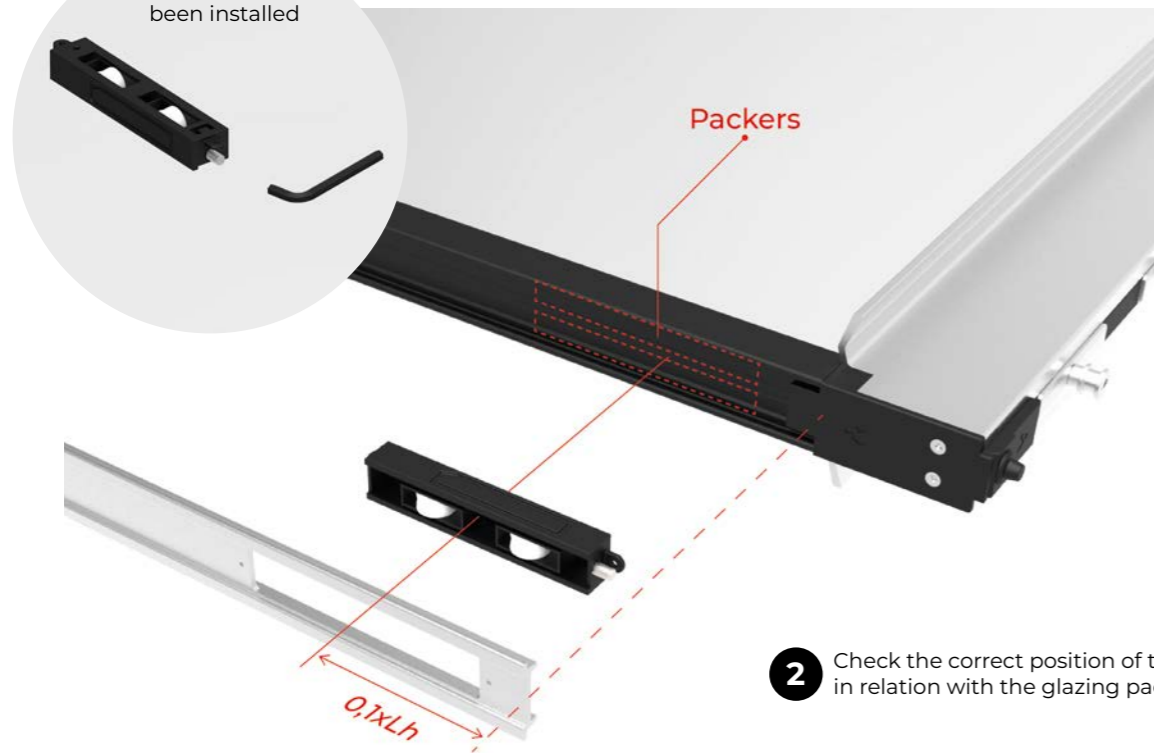

- 2** Check the correct position of the roller in relation with the glazing packers

Installation Guide

- 3** Insert top of sash into top track channel.

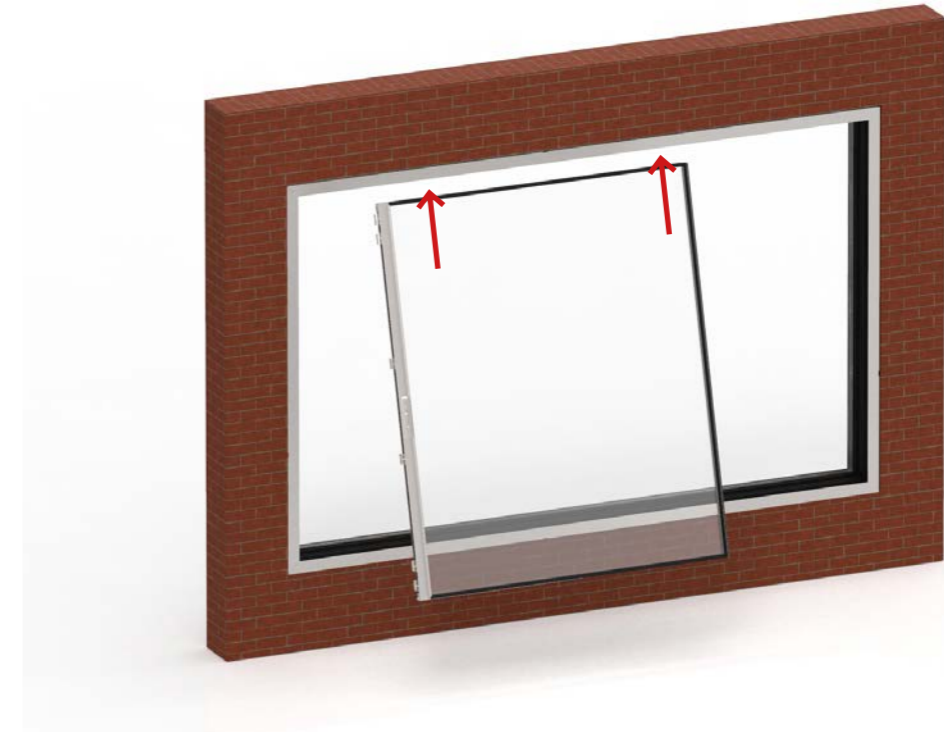

- 4** Swing bottom of sash above running gear.

Installation Guide

- 5** Drop correctly on to bearing profiles, ensuring sits within the bottom of the sash.



Installation Guide

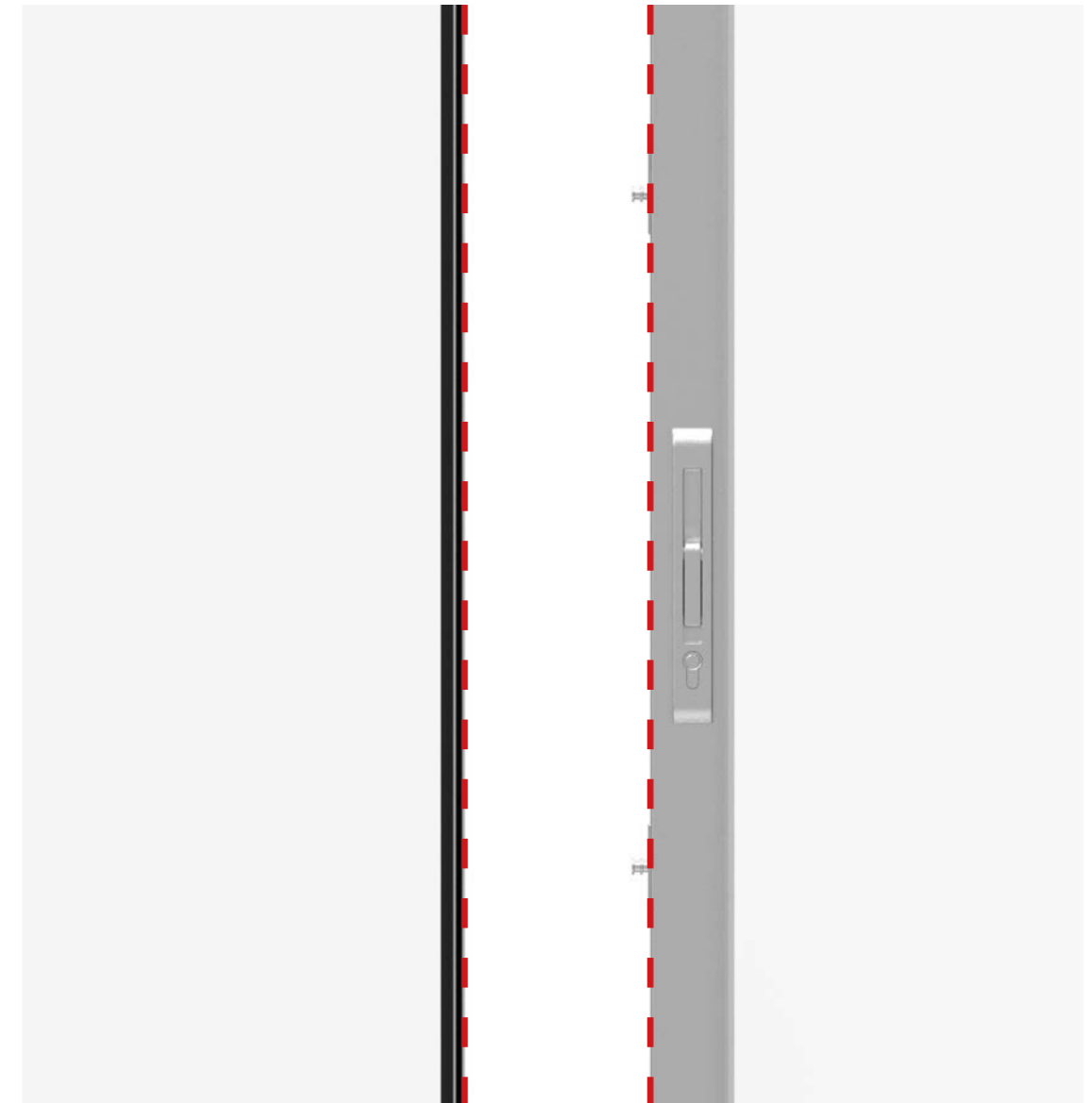

- 7** Level the sash to ensure is parallel to the frame. Repeat for all opening sashes to ensure the interlock line up correctly.

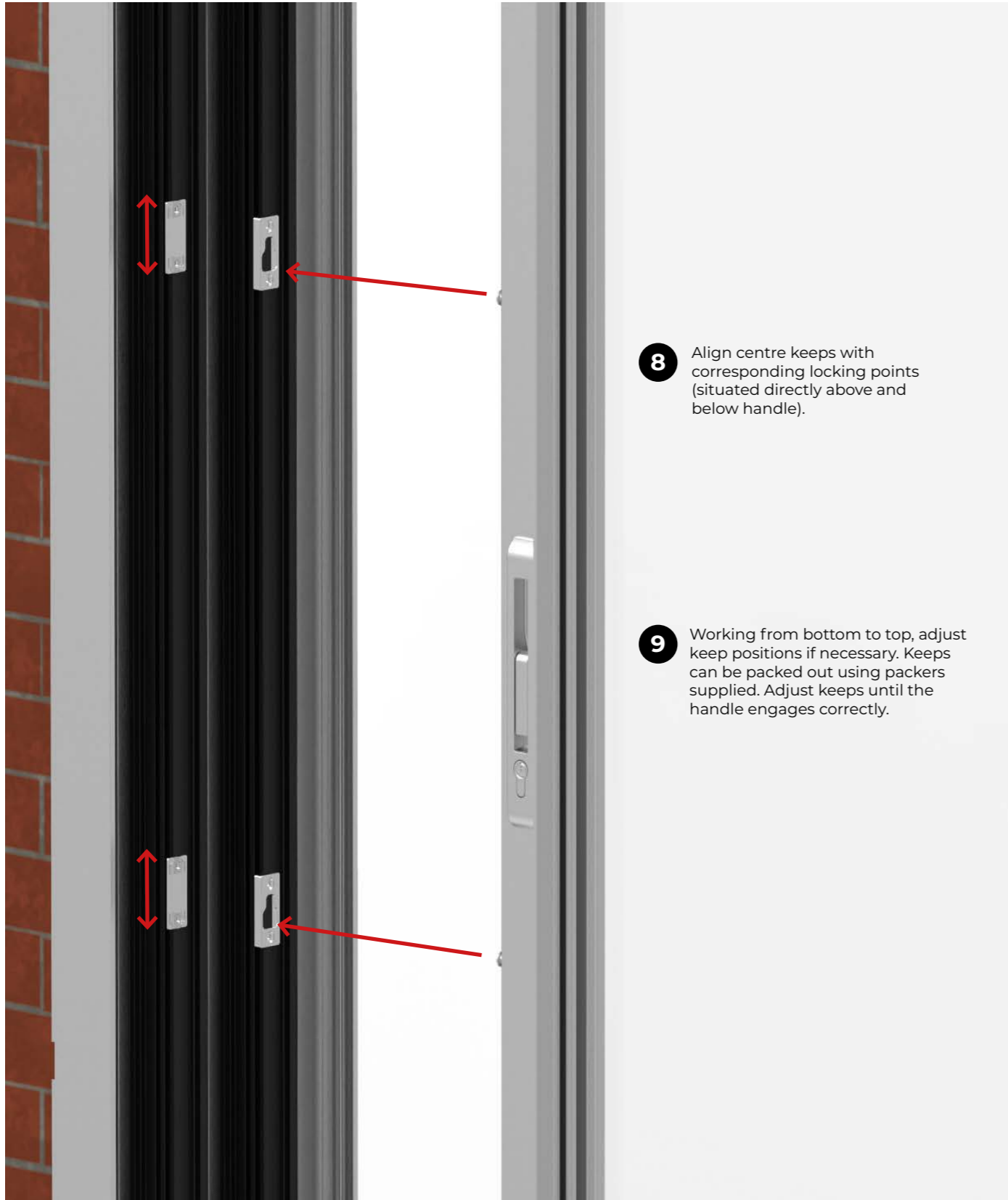

10 If more adjustment is required, use an allen Key to adjust the locking point.

Lock and counter lock microventilation

Cased in frame with Microventilation lock

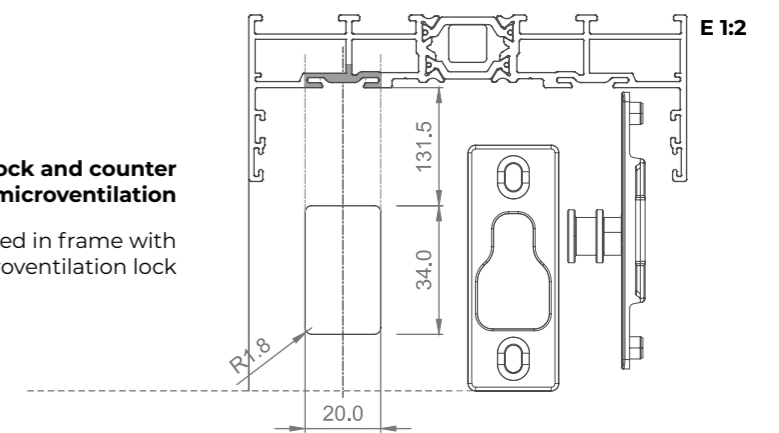

Installation Guide

10. If applicable, install the fixed panel



Installation Guide

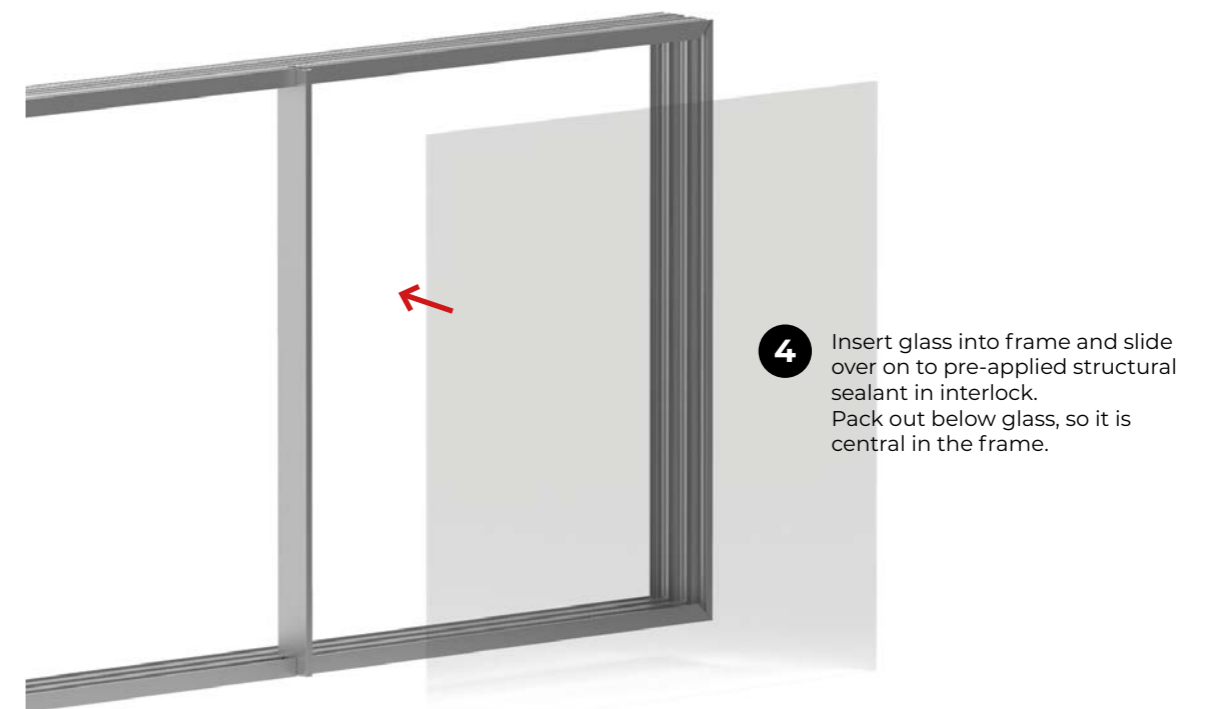
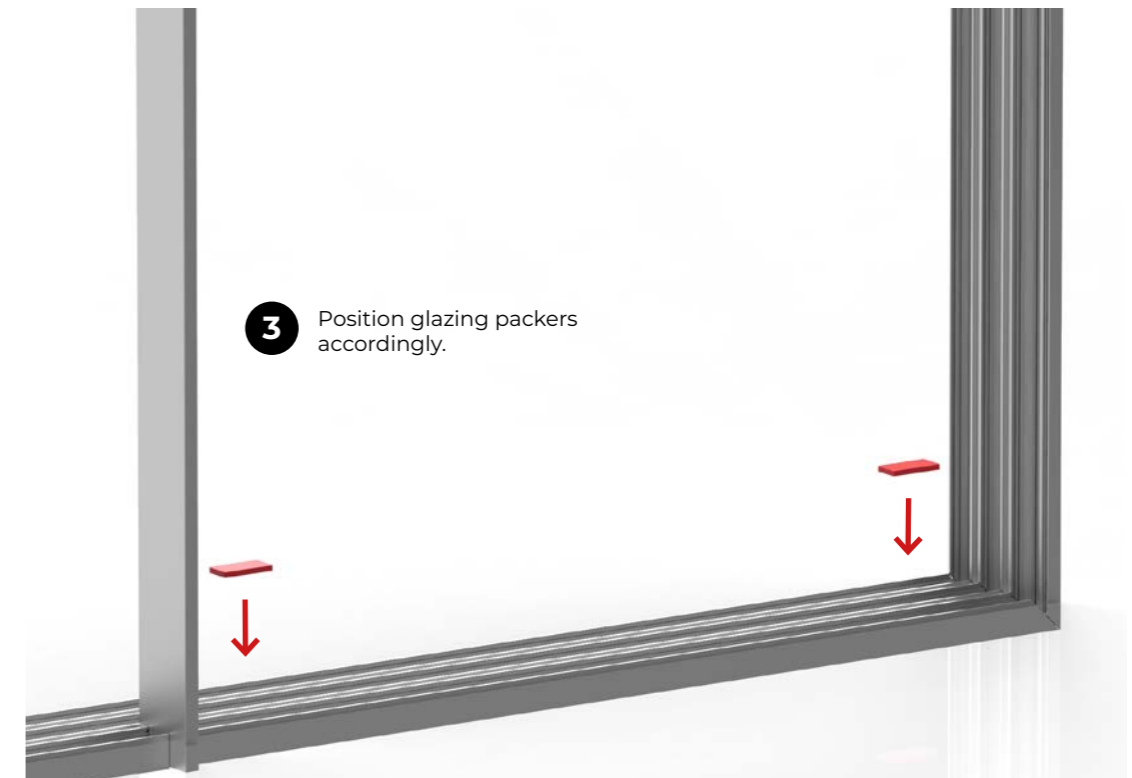

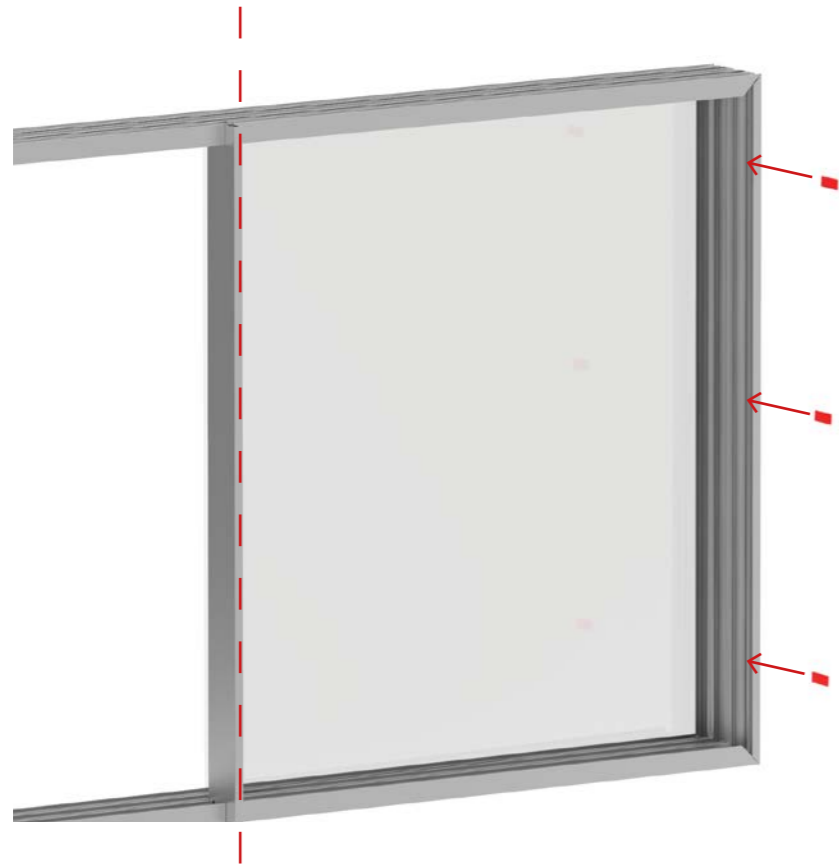

5 Position glazing packers accordingly.

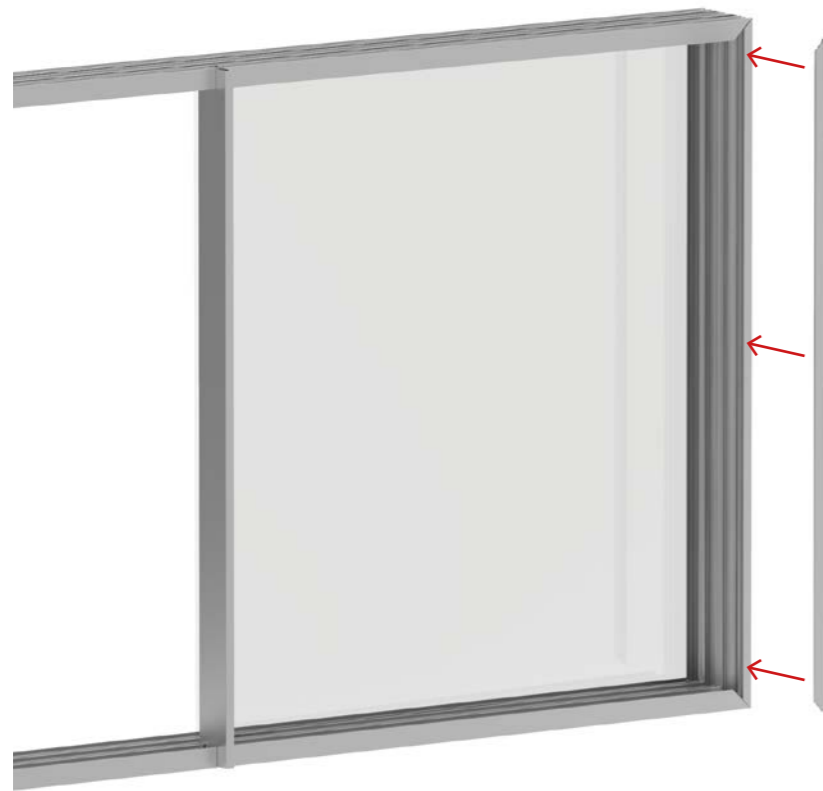

6 Secure frame bead in place.

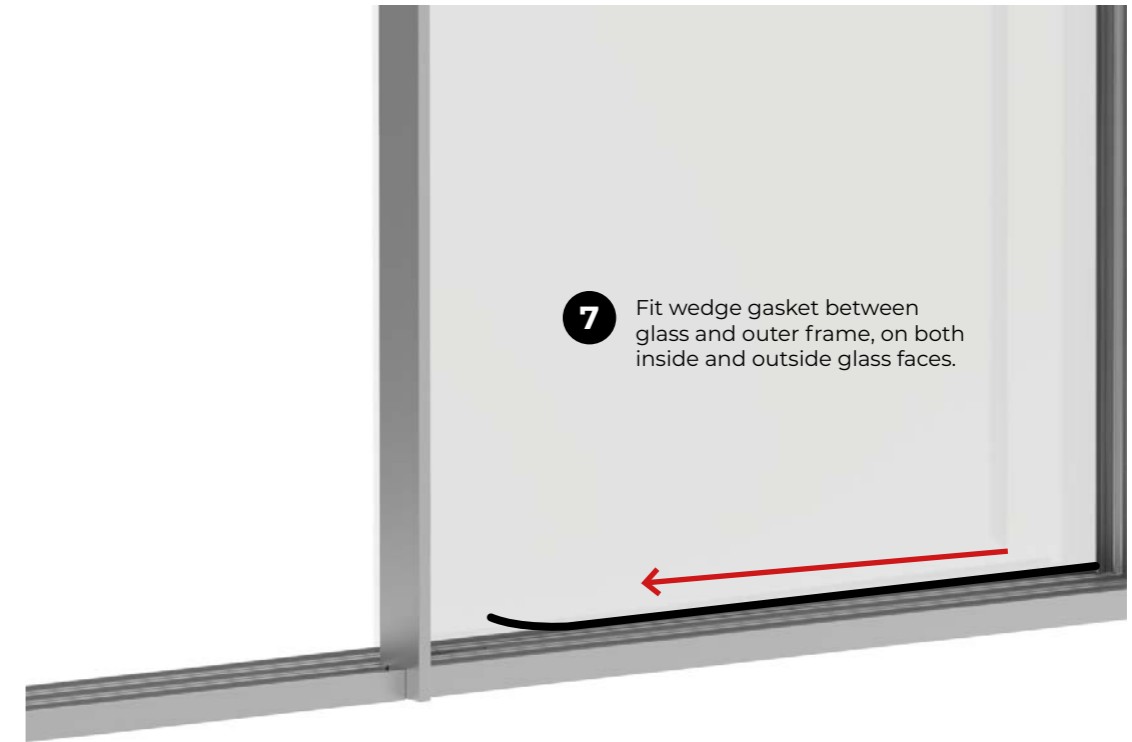

7 Fit wedge gasket between glass and outer frame, on both inside and outside glass faces.

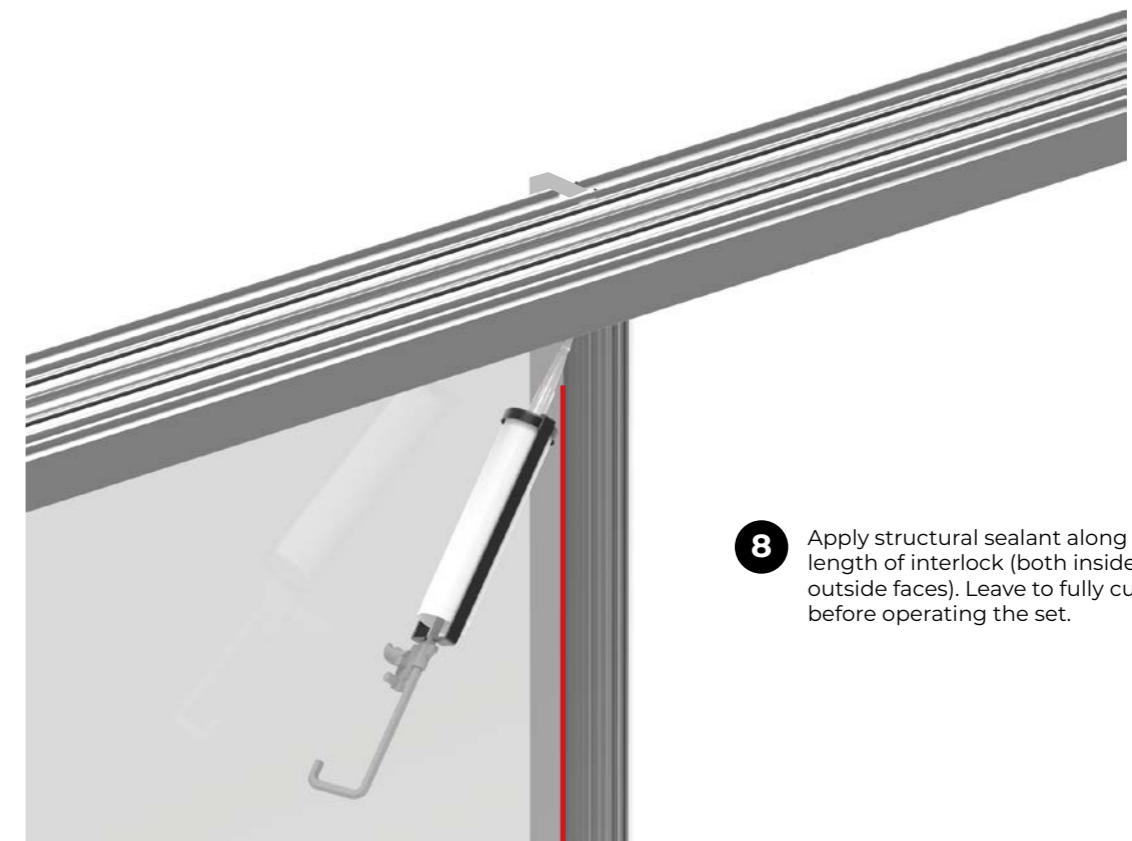

8 Apply structural sealant along the length of interlock (both inside and outside faces). Leave to fully cure before operating the set.

Installation Guide

11. Install frame covers



